

Crankcase pressure regulator, type KVL

Contents

	Page
Introduction.....	3
Features.....	3
Approval.....	3
Technical data.....	3
Ordering.....	3
Capacities:	
R 22.....	4
R 134a.....	5
R 404A/R507.....	6
R 407C.....	7
Sizing.....	8
Valve selection.....	8
Design / Function.....	9
P-band and Offset.....	9
Dimensions and weights.....	10

Introduction

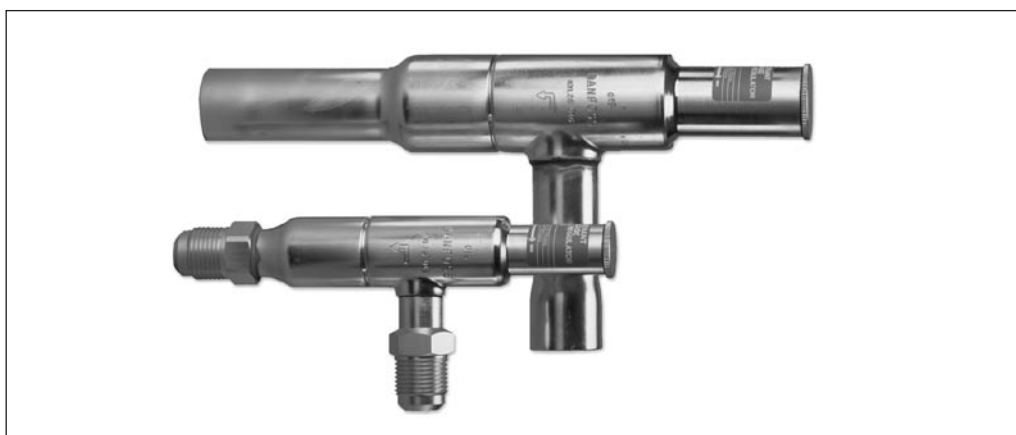

Crankcase pressure regulator type KVL is fitted in the suction line ahead of the compressor. The KVL protects the compressor motor against

overload during start-up after long standstill periods or after defrost periods (high pressure in evaporator).

Features

- Accurate, adjustable pressure regulation
- Wide capacity and operating ranges
- Pulsation damping design
- Stainless steel bellows
- Compact angle design for easy installation in any position
- "Hermetic" brazed construction
- Available in a wide size range of flare and ODF solder types
- For CFC, HCFC og HFC

Approval

CE US approved, file SA7200

Technical data

Refrigerants
CFC, HCFC, HFC

Regulating range
0.2 → 6 bar
Factory setting: 2.0 bar

Maximum working pressure
PS = 18 bar

Max. test pressure
KVL 12 → 22: p` = 28 bar
KVL 28 → 35: p` = 25.6 bar

Maximum temperature of medium
130°C

Minimum temperature of medium
-60°C

Maximum P-band
KVL 12 → 22: 2.0 bar
KVL 28 → 35: 1.5 bar

k_v-value ¹⁾ at maximum P-band
KVL 12 → 22: 3,2 m³/h
KVL 28 → 35: 8.0 m³/h

¹⁾ The k_v-value is the flow of water in m³/h at a pressure drop across valve of 1 bar, ρ = 1000 kg/m³.

Ordering

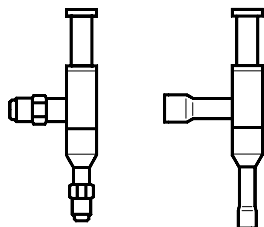

Type	Rated capacity ¹⁾ kW				Flare connection		Code no.	Solder connection		Code no.
	R22	R134a	R404A / R507	R407C	in.	mm		in.	mm	
KVL 12	7.1	5.3	6.3	6.4	1/2	12	034L0041	1/2		034L0043
									12	
KVL 15	7.1	5.3	6.3	6.5	5/8	16	034L0042	5/8	16	034L0049
KVL 22	7.1	5.3	6.3	6.5				7/8	22	034L0045
KVL 28	17.8	13.2	15.9	16.4				1 1/8		034L0046
									28	034L0051
KVL 35	17.8	13.2	15.9	16.4				1 3/8	35	034L0052

¹⁾ Rated capacity is the regulator capacity at suction temperature t_s = -10°C condensing temperature t_c = +25°C pressure drop in regulator Δp = 0.2 bar

KVL supplied without flare nuts. Separate flare nuts can be supplied: 1/2 in. / 12 mm, code no. 011L1103 3/8 in. / 16 mm, code no. 011L1167

The connection dimensions chosen must not be too small, since gas velocities in excess of 40 m/s in the inlet of the regulator can give flow noise.

Capacity
R22
Max. regulator capacity Q_e ¹⁾

Type	Pressure drop in regulator Δp bar	Maximum suction pressure p_s bar	Capacity Q_e in kW at suction temperature t_s after the regulator, °C															
			-35	-30	-25	-20	-15	-10	-5	0	+5	+10	+15					
KVL 12 KVL 15 KVL 22	0.1	1	1.9	1.2														
		2	3.0	3.3	3.1	2.1	0.2											
		3	3.0	3.3	3.7	4.1	4.0	2.2										
		4	3.0	3.3	3.7	4.1	4.6	5.0	3.9	0.1								
		5	3.0	3.3	3.7	4.1	4.6	5.0	5.5	5.2	1.0							
		6	3.0	3.3	3.7	4.1	4.6	5.0	5.5	6.0	6.2	1.3						
	0.2	1	2.6	1.7														
		2	4.2	4.7	4.4	3.0	0.2											
		3	4.2	4.7	5.3	5.9	5.6	3.1										
		4	4.2	4.7	5.3	5.9	6.5	7.1	5.5	0.1								
		5	4.2	4.7	5.3	5.9	6.5	7.1	7.8	7.3								
		6	4.2	4.7	5.3	5.9	6.5	7.1	7.8	8.5	8.7	1.9						
	0.3	1	3.2	2.0														
		2	5.2	5.8	5.4	3.7	0.3											
		3	5.2	5.8	6.5	7.2	6.9	3.8										
		4	5.2	5.8	6.5	7.2	8.0	8.8	6.7	0.2								
		5	5.2	5.8	6.5	7.2	8.0	8.8	9.6	9.0	1.7							
		6	5.2	5.8	6.5	7.2	8.0	8.8	9.6	10.5	10.7	2.3						
KVL 28 KVL 35	0.1	1	4.1	2.6														
		2	7.4	7.9	7.0	4.6	0.4											
		3	7.4	8.3	9.3	10.3	8.9	4.7										
		4	7.4	8.3	9.3	10.3	11.4	12.3	8.5	0.2								
		5	7.4	8.3	9.3	10.3	11.4	12.6	13.8	11.6	2.2							
		6	7.4	8.3	9.3	10.3	11.4	12.6	13.8	15.1	13.9	2.8						
	0.2	1	5.8	3.6														
		2	10.6	11.2	9.8	6.5	0.5											
		3	10.6	11.8	13.2	14.7	12.5	6.6										
		4	10.6	11.8	13.2	14.7	16.2	17.5	12.0	0.3								
		5	10.6	11.8	13.2	14.7	16.2	17.8	19.6	16.4	3.1							
		6	10.6	11.8	13.2	14.7	16.2	17.8	19.6	21.4	19.6	4.0						
	0.3	1	7.0	4.4														
		2	13.0	13.8	12.1	8.0	0.6											
		3	13.0	14.6	16.3	18.0	15.4	8.1										
		4	13.0	14.6	16.3	18.0	19.9	21.5	14.7	0.3								
		5	13.0	14.6	16.3	18.0	19.9	21.9	24.1	20.0	3.7							
		6	13.0	14.6	16.3	18.0	19.9	21.9	24.1	26.3	24.1	4.9						

¹⁾ The values in the capacity tables refer to the evaporator capacity and are based on liquid temperature $t_l = +25^\circ\text{C}$

Correction factors for liquid temperature t_l

t_l °C	10	15	20	25	30	35	40	45	50
R22	0.90	0.93	0.96	1.0	1.05	1.10	1.13	1.18	1.24

Plant capacity \times correction factor = the values in the table

Capacity (continued)

R134a

 Max. regulator capacity Q_e ¹⁾

Type	Pressure drop in regulator Δp bar	Maximum suction pressure p_s bar	Capacity Q_e in kW at suction temperature t_s after the regulator, °C															
			-30	-25	-20	-15	-10	-5	0	+5	+10	+15	+20					
KVL 12 KVL 15 KVL 22	0.1	1			1.8	1.2												
		2			2.9	3.3	3.1	2.2	0.3									
		3			2.9	3.3	3.7	4.1	4.1	2.4								
		4			2.9	3.3	3.7	4.1	4.6	5.1	4.2	0.7						
		5			2.9	3.3	3.7	4.1	4.6	5.1	5.6	5.6					1.8	
		6			2.9	3.3	3.7	4.1	4.6	5.1	5.6	5.6	6.2				6.7	
	0.2	1			2.6	1.6												
		2			4.2	4.7	4.4	3.1	0.4									
		3			4.2	4.7	5.3	5.9	5.8	3.4								
		4			4.2	4.7	5.3	5.9	6.5	7.2	5.9	0.9						
		5			4.2	4.7	5.3	5.9	6.5	7.2	7.9	8.0	2.6					
		6			4.2	4.7	5.3	5.9	6.5	7.2	7.9	9.5	8.7					
	0.3	1			3.2	2.0												
		2			5.2	5.8	5.5	3.8	0.5									
		3			5.2	5.8	6.5	7.2	7.1	4.2								
		4			5.2	5.8	6.5	7.2	8.0	8.9	7.3	1.1						
		5			5.2	5.8	6.5	7.2	8.0	8.9	9.8	9.8	3.2					
		6			5.8	6.5	7.2	8.0	8.9	9.8	10.7	10.7	11.7					
KVL 28 KVL 35	0.1	1			4.0	2.5												
		2			7.3	7.8	6.9	4.8	0.6									
		3			7.3	8.2	9.3	10.3	9.1	5.2								
		4			7.3	8.2	9.3	10.3	11.5	12.7	9.2	1.4						
		5			7.3	8.2	9.3	10.3	11.5	12.7	14.0	12.6	3.9					
		6			7.3	8.2	9.3	10.3	11.5	12.7	14.0	15.4	15.3					
	0.2	1			5.6	3.5												
		2			10.5	11.1	9.8	6.7	0.9									
		3			10.5	11.8	13.2	14.7	12.9	7.3								
		4			10.5	11.8	13.2	14.7	16.3	18.1	13.1	2.0						
		5			10.5	11.8	13.2	14.7	16.3	18.1	19.9	17.8	5.6					
		6			10.5	11.8	13.2	14.7	16.3	18.1	19.9	21.9	21.7					
	0.3	1			6.9	4.3												
		2			12.9	13.7	12.1	8.2	1.1									
		3			12.9	14.5	16.2	18.1	15.8	9.0								
		4			12.9	14.5	16.2	18.1	20.1	22.2	24.5	21.9	6.8					
		5			12.9	14.5	16.2	18.1	20.1	22.2	24.5	26.9	26.6					
		6			12.9	14.5	16.2	18.1	20.1	22.2	24.5	26.9	26.6					

¹⁾ The values in the capacity tables refer to the evaporator capacity and are based on liquid temperature $t_l = +25^\circ\text{C}$

 Correction factors for liquid temperature t_l

t_l °C	10	15	20	25	30	35	40	45	50
R134a	0.88	0.92	0.96	1.0	1.05	1.10	1.16	1.23	1.31

 Plant capacity \times correction factor = the values in the table

Capacity (continued)

R404A / R507

 Max. regulator capacity Q_e ¹⁾

Type	Pressure drop in regulator Δp bar	Maximum suction pressure p_s bar	Capacity Q_e in kW at suction temperature t_s after the regulator, °C															
			-35	-30	-25	-20	-15	-10	-5	0	+5	+10	+15					
KVL 12 KVL 15 KVL 22	0.1	1	0.9															
		2	2.5	2.4	1.7	0.3												
		3	2.5	2.9	3.2	3.2	1.9											
		4	2.5	2.9	3.2	3.6	4.0	3.4	0.5									
		5	2.5	2.9	3.2	3.6	4.0	4.5	4.5	1.5								
		6	2.5	2.9	3.2	3.6	4.0	4.5	4.9	5.5	2.1							
	0.2	1	1.3															
		2	3.6	3.4	2.5	0.4												
		3	3.6	4.0	4.6	4.5	2.7											
		4	3.6	4.0	4.6	5.1	5.7	4.8	0.8									
		5	3.6	4.0	4.6	5.1	5.7	6.3	6.4	2.2								
		6	3.6	4.0	4.6	5.1	5.7	6.3	7.0	7.8	2.9							
	0.3	1	1.6															
		2	4.4	4.2	3.0	0.4												
		3	4.4	5.0	5.6	5.6	3.3											
		4	4.4	5.0	5.6	6.3	7.0	5.9	1.0									
		5	4.4	5.0	5.6	6.3	7.0	7.8	7.8	2.6								
		6	4.4	5.0	5.6	6.3	7.0	7.8	8.6	9.6	3.5							
KVL 28 KVL 35	0.1	1	2.0															
		2	5.9	5.4	3.7	0.5												
		3	6.2	7.1	8.0	7.2	4.2											
		4	6.2	7.1	8.0	9.1	10.0	7.4	1.2									
		5	6.2	7.1	8.0	9.1	10.0	11.2	10.1	3.3								
		6	6.2	7.1	8.0	9.1	10.0	11.2	12.4	12.4	4.4							
	0.2	1	2.7															
		2	8.4	7.6	5.4	0.9												
		3	8.9	10.1	11.4	10.3	5.9											
		4	8.9	10.1	11.4	12.9	14.3	10.6	1.7									
		5	8.9	10.1	11.4	12.9	14.3	15.9	14.4	4.6								
		6	8.9	10.1	11.4	12.9	14.3	15.9	17.5	17.6	6.3							
	0.3	1	3.4															
		2	10.4	9.3	6.5	1.1												
		3	10.9	12.5	14.0	12.5	7.2											
		4	10.9	12.5	14.0	15.8	17.6	13.0	2.1									
		5	10.9	12.5	14.0	15.8	17.6	19.6	17.7	5.6								
		6	10.9	12.5	14.0	15.8	17.6	19.6	21.6	21.7	7.7							

¹⁾ The values in the capacity tables refer to the evaporator capacity and are based on liquid temperature $t_l = +25^\circ\text{C}$

 Correction factors for liquid temperature t_l

t_l °C	10	15	20	25	30	35	40	45	50
R404A / R507	0.84	0.89	0.94	1.0	1.07	1.16	1.26	1.40	1.57

Plant capacity × correction factor = the values in the table

Capacity (continued)
R407C
Max. regulator capacity Q_e ¹⁾

Type	Pressure drop in regulator Δp bar	Maximum suction pressure P_s bar	Capacity Q_e in kW at suction temperature t_s after the regulator, °C																
			-35	-30	-25	-20	-15	-10	-5	0	+5	+10	+15						
KVL 12 KVL 15 KVL 22	0.1	1	1.6	1.0															
		2	2.5	2.8	2.7	1.9	0.2												
		3	2.5	2.8	3.2	3.6	3.6	2.0											
		4	2.5	2.8	3.2	3.6	4.1	4.6	3.6	0.1									
		5	2.5	2.8	3.2	3.6	4.1	4.6	5.1	4.9	1.0								
		6	2.5	2.8	3.2	3.6	4.1	4.6	5.1	5.6	6.0	1.3							
	0.2	1	2.2	1.5															
		2	3.5	4.0	3.8	2.7	0.2												
		3	3.5	4.0	4.6	5.3	5.0	2.9											
		4	3.5	4.0	4.6	5.3	5.9	6.5	5.1	0.1									
		5	3.5	4.0	4.6	5.3	5.9	6.5	7.3	6.9									
		6	3.5	4.0	4.6	5.3	5.9	6.5	7.3	8.0	8.4	1.8							
	0.3	1	2.7	1.7															
		2	4.4	5.0	4.7	3.3	0.3												
		3	4.4	5.0	5.7	6.4	6.2	3.5											
		4	4.4	5.0	5.7	6.4	7.2	8.1	6.2	0.2									
		5	4.4	5.0	5.7	6.4	7.2	8.1	8.9	8.5	1.6								
		6	4.4	5.0	5.7	6.4	7.2	8.1	8.9	9.9	10.3	2.2							
KVL 28 KVL 35	0.1	1	3.4	2.2															
		2	6.2	6.8	6.1	4.1	0.4												
		3	6.2	7.1	8.1	9.2	8.0	4.3											
		4	6.2	7.1	8.1	9.2	10.3	11.3	7.9	0.2									
		5	6.2	7.1	8.1	9.2	10.3	11.6	12.8	10.9	2.1								
		6	6.2	7.1	8.1	9.2	10.3	11.6	12.8	14.2	13.3	2.7							
	0.2	1	4.9	3.1															
		2	8.9	9.6	8.5	5.8	0.2												
		3	8.9	10.1	11.5	13.1	11.3	6.1											
		4	8.9	10.1	11.5	13.1	14.6	16.1	11.2	0.3									
		5	8.9	10.1	11.5	13.1	14.6	16.4	18.2	15.4	3.0								
		6	8.9	10.1	11.5	13.1	14.6	16.4	18.2	20.1	18.8	3.9							
	0.3	1	5.9	3.8															
		2	10.9	11.9	10.5	7.1	0.5												
		3	10.9	12.6	14.2	16.0	13.9	7.5											
		4	10.9	12.6	14.2	16.0	17.9	19.8	13.7	0.3									
		5	10.9	12.6	14.2	16.0	17.9	20.1	22.4	18.8	3.6								
		6	10.9	12.6	14.2	16.0	17.9	20.1	22.4	24.7	23.1	4.8							

¹⁾ The values in the capacity tables refer to the evaporator capacity and are based on liquid temperature $t_l = +25^\circ\text{C}$

Correction factors for liquid temperature t_l

t_l °C	10	15	20	25	30	35	40	45	50
R407C	0.88	0.91	0.95	1.0	1.05	1.11	1.18	1.26	1.35

Plant capacity \times correction factor = the values in the table

Sizing

For optimum performance, it is important to select a KVL valve according to system conditions and application.

The following data must be used when sizing a KVL valve:

- Refrigerant - CFC, HCFC or HFC
- Evaporating capacity Q_e in kW
- Liquid temperature ahead of expansion valve t_l in °C
- Suction temperature ahead of compressor t_s in °C
- Maximum suction pressure after the regulator p_s in bar
- Connection type: flare or solder
- Connection size in inches or mm

Valve selection

(Example)

When selecting the appropriate valve it may be necessary to convert the actual evaporator capacity using a correction factor. This is required when your system conditions are different than the table conditions.

The selection is also dependant on the acceptable pressure drop across the valve. The following example illustrates how this is done.

Refrigerant: R404A
 Evaporating capacity: 4.0 kW
 Liquid temperature ahead of expansion valve: 35°C
 Suction temperature ahead of compressor: -25°C
 Maximum suction pressure after the regulator: 3.8 bar ~ -7°C
 Connection type: solder
 Connection size: $\frac{5}{8}$ in.

Step 1

Determine the correction factor for liquid temperature t_l ahead of expansion valve.

From the correction factors table (see below) the correction factor for a liquid temperature at 35°C (R 404A) corresponds to a factor of 1.16.

Correction factors for liquid temperature t_l

t_l °C	10	15	20	25	30	35	40	45	50
R134a	0.88	0.92	0.96	1.0	1.05	1.10	1.16	1.23	1.31
R22	0.90	0.93	0.96	1.0	1.05	1.10	1.13	1.18	1.24
R404A/ R507	0.84	0.89	0.94	1.0	1.07	1.16	1.26	1.40	1.57
R407C	0.88	0.91	0.95	1.0	1.05	1.11	1.18	1.26	1.35

Step 2

The corrected evaporating capacity is
 $Q_e = 4.0 \times 1.16 = 4.64$ kW

Step 3

Now select the capacity table for R 404A and choose the column with a suction temperature of -25°C. Using the corrected replacement capacity, select a valve that provides an equivalent or greater capacity than required.

KVL 12/15/22 delivers a capacity of 4.6 kW at a pressure drop of 0.2 bar across the valve and 5.6 kW at a pressure drop of 0.3 bar across the valve. Based on the required connection size of $\frac{5}{8}$ in. the KVL 15 valve is the proper selection for this example.

Step 4

KVL 15, $\frac{5}{8}$ in. solder connection
code. no. 034L0049, see ordering list.

Design Function

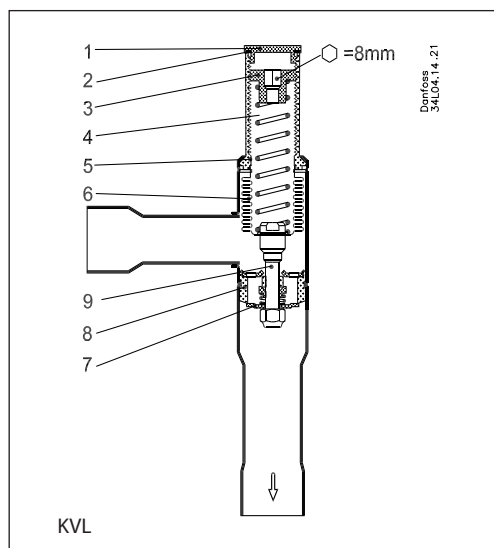

- 1. Protective cap
- 2. Gasket
- 3. Setting screw
- 4. Main spring
- 5. Valve body
- 6. Equalization bellows
- 7. Valve plate
- 8. Valve seat
- 9. Damping device

The Crankcase pressure regulator type KVL opens at pressure fall on the outlet side, i.e. when the suction pressure ahead of the compressor drops below the set value.

The KVL only regulates based on the outlet pressure. Pressure variations on the inlet side of the regulator do not affect the degree of opening since the KVL is equipped with an equalization bellows (6). This bellows has an effective area corresponding to that of the valve seat.

The regulator is also equipped with an effective damping device (9) against pulsations, which normally occur in a refrigeration plant. The damping device helps to ensure long life of the regulator without impairing regulation accuracy.

P-band and Offset

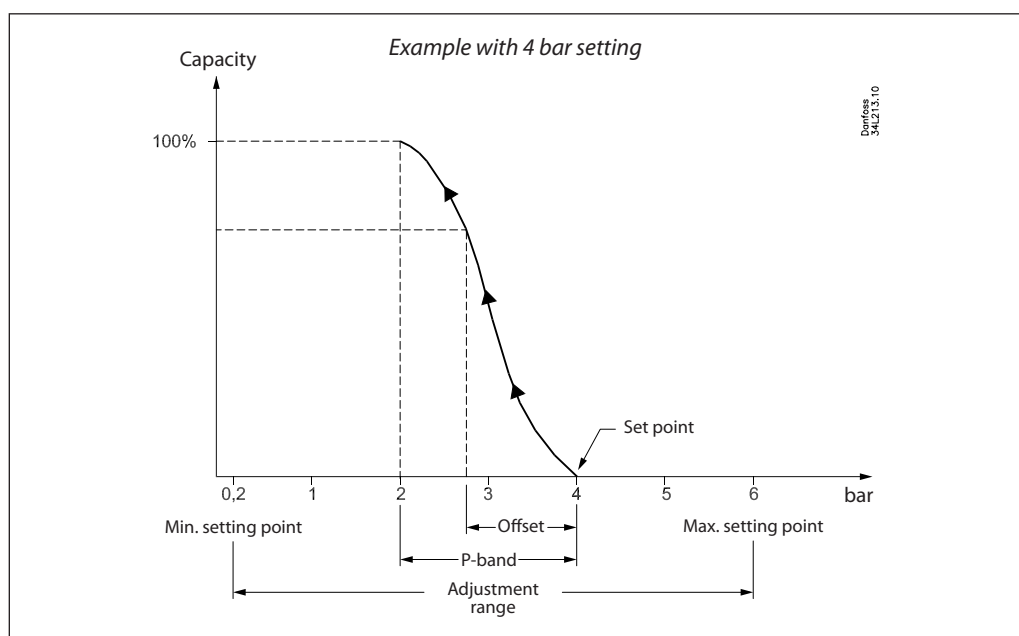

Proportional band

The p-band is defined as the difference between the pressure at which the valve plate starts to open (set point) and the pressure at which the valve is completely open.

Example:

If the valve is set to open at 4 bar and the valve p-band is 2 bar, the valve will give maximum capacity when the outlet pressure reaches 2 bar.

Offset:

The offset is defined as the difference between the pressure at which the valve plate starts to open (set point) and the pressure at which the valve reaches the necessary opening for the actual load.

The offset is always a part of the p-band. Because optimal function of a refrigeration plant is best reached with fully open KVL, the term offset is normally not used in connection with the KVL valve.

Dimensions and weights

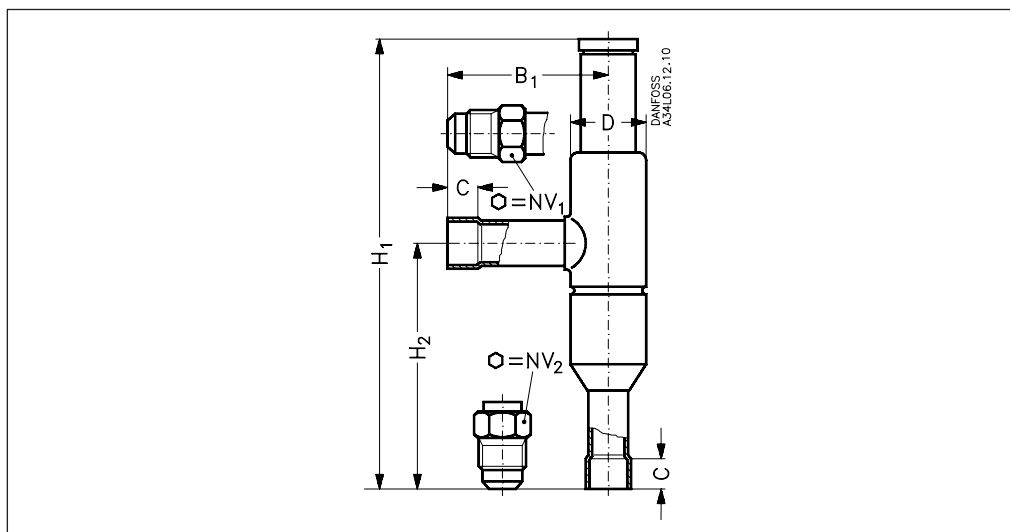

Type	Connection		H ₁ mm	H ₂ mm	B ₁ mm	C solder mm	Ø D mm	Weight kg
	Flare	Solder ODF						
KVL 12	1/2 in. / 12 mm	1/2 in. / 12 mm	179	99	64	10	30	0.4
KVL 15	5/8 in. / 16 mm	5/8 in. / 16 mm	179	99	64	12	30	0.4
KVL 22		7/8 in. / 22 mm	179	99	64	17	30	0.4
KVL 28		1 1/8 in. / 28 mm	259	151	105	20	43	1.0
KVL 35		1 3/8 in. / 35 mm	259	151	105	25	43	1.0

