

The TI series has interchangeable cages capable of changing valve capacity in the field.

Features

- Stainless steel power element eliminates corrosion and prevents valve failure
- Wrench flats on inlet and outlet
- Forged brass valve body
- Inlet strainer assembly



Options

- Interchangeable capacity cages

Specifications

- Inlet connection size: 3/8" SAE, Outlet 1/2" SAE
- Maximum working pressure: 450 psig
- Maximum bulb temperature: 165°F

Nomenclature example: TIE4 HW

TI	E	4	H	W
Valve Series	Equalizer E=External (Omit for internal)	Orifice Size Valves sold less cage (Select proper cage from interchangeability table below)	Refrigerant Code • H = R-22 • M = R-134a • N = R-407C *P = R-507 *S = R-404A	Charge Code W = medium temp W(MOP) = press. limiting

- * = R-507 and R-404a are interchangeable refrigerant charges
- = R-22 and R-407C are interchangeable refrigerant charges

Interchangeable Cages

Cage Size	Type	PCN	Nominal Capacity (kW)		
			R-134a	R-22/R-407C	R-404A/R-507
00	TIO-00X	065087	0.03	0.05	0.04
0	TIO-000	065088	0.08	1.30	1.00
1	TIO-001	065090	1.90	3.20	2.30
2	TIO-002	065091	3.10	5.30	3.90
3	TIO-003	065092	5.00	8.50	6.20
4	TIO-004	065093	8.30	13.90	10.10
5	TIO-005	065094	10.10	16.90	12.30
6	TIO-006	065095	11.70	19.50	14.20

NOTE: Nominal capacities shown on pages at the end of this section are based on European standards of +38°C condensing temperature, +4°C evaporating temperature and 1°K liquid subcooling at the inlet of the expansion valve. This methodology varies from the rest of the capacity tables in this catalog.

Dimensional Data (in)

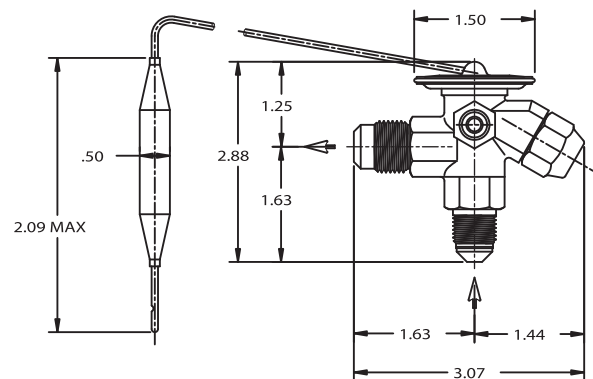

TI(E) Series – Valve bodies, Flare type

Evaporating Temp Range °F	Equalizer Type	Refrigerant					
		R-134a		R-22/R-407C		R-404A/R-507	
		Valve	PCN	Valve	PCN	Valve	PCN
-10 to +40	internal	TI-MW	065016	TI-HW	065020	TI-SW	065028
	external	TIE-MW	065017	TIE-HW	065021	TIE-SW	065031